

  
**UNITECH**  
PROFILES 



Enhancing Homes  
With Stylish And  
Durable Window  
Solutions

**UPVC**

WINDOWS & DOOR PROFILES

[www.unitechprofiles.com](http://www.unitechprofiles.com)



# CASEMENT SERIES

Practical and Simple, designed to suit your home whatever is its style, **Unitech Profile** upvc casement windows are among the most popular window designs. Hard-wearing material used in **Unitech Profile** casement windows is virtually maintenance-free.

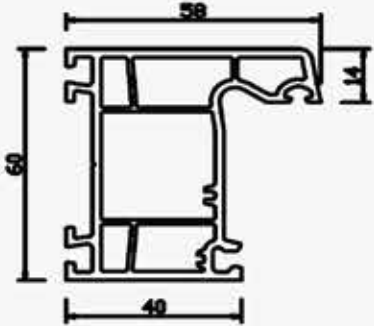
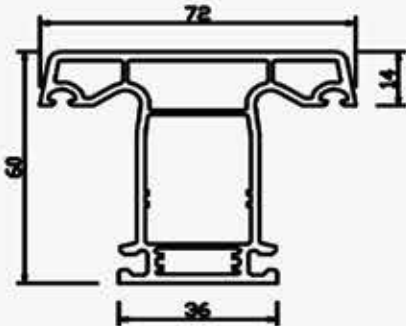
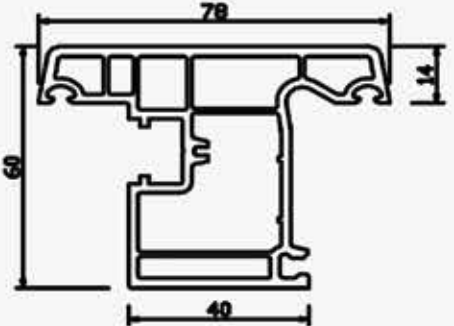
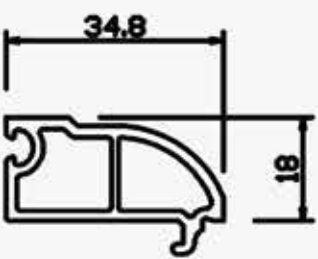
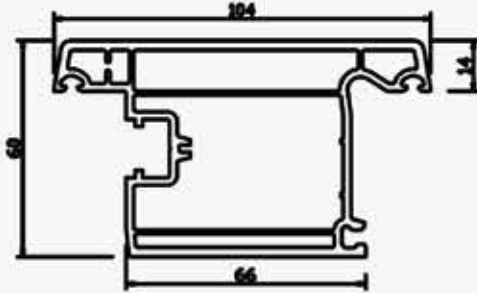
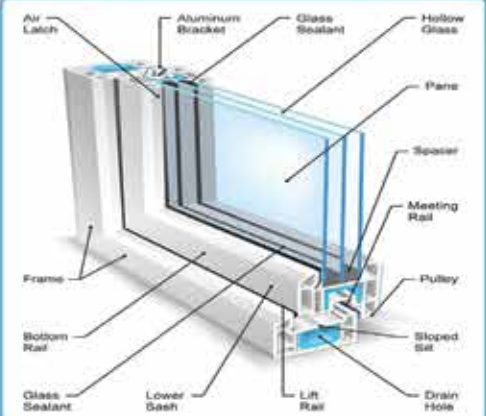
		
<p><b>60 OUTER FRAME</b> Thickness : 2.3 MM</p>	<p><b>CASEMENT MULLION</b> Thickness : 2.3 MM</p>	<p><b>60 OUTER SWING SASH</b> Thickness : 2.5 MM</p>
<p>Length 5.9 Mtr      1.04 Kg / Mtr</p>	<p>Length 5.9 Mtr      1.07 Kg / Mtr</p>	<p>Length 5.9 Mtr      1.29 Kg / Mtr</p>
		<p><b>Window Frame Cross-Section</b></p> 
<p><b>SINGLE GLAZING BEAD</b> Thickness : 2.0 MM</p>	<p><b>60 OUTER SWING DOOR SASH</b> Thickness : 2.7 MM</p>	
<p>Length 5.9 Mtr      0.33 Kg / Mtr</p>	<p>Length 5.9 Mtr      1.62 Kg / Mtr</p>	





# LOTUS SLIDING SERIES

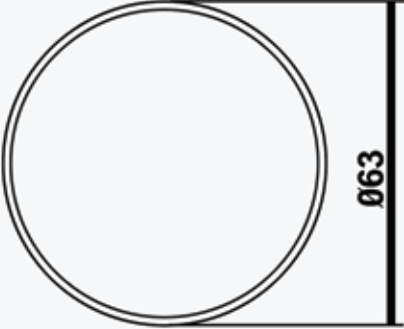

The stylish and contemporary **Sliding windows** are highly energy-efficient. Sliding windows offer increased security with grills, multi-lock points, etc. The windows are highly durable and long-lasting. They are robust in features and do not expand or contract due of weather conditions.

<p><b>Sliding Two Track Frame</b> Thickness : 2.3MM</p>	<p><b>Sliding 2.5 Track</b> Thickness : 2.3MM</p>	<p><b>SLIDING 3 TRACK</b> Thickness : 2.3MM</p>
<p>Length 5.8 Mtr      1.13 Kg / Mtr</p>	<p>Length 5.8 Mtr      1.46 Kg / Mtr</p>	<p>Length 5.8 Mtr      1.72 Kg / Mtr</p>
<p><b>57 SASH</b> Thickness : 2.3 MM</p>	<p><b>66 SASH</b> Thickness : 2.3 MM</p>	<p><b>86 SASH</b> Thickness : 2.3 MM</p>
<p>Length 5.8 Mtr      0.88 Kg / Mtr</p>	<p>Length 5.8 Mtr      1.0 Kg / Mtr</p>	<p>Length 5.8 Mtr      1.32 Kg / Mtr</p>
<p><b>MESH SCREEN SASH</b> Thickness : 2.3 MM</p>	<p><b>SINGLE GLAZING BEAD</b> Thickness : 2.3 MM</p>	<p><b>SLIDING WINDOW INTERLOCK</b> Thickness : 2.3 MM</p>
<p>Length 5.8 Mtr      0.55 Kg / Mtr</p>	<p>Length 5.8 Mtr      0.24 Kg / Mtr</p>	<p>Length 5.8 Mtr      0.22 Kg / Mtr</p>

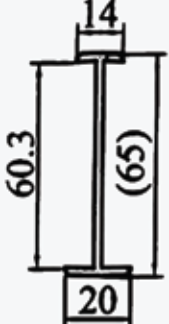
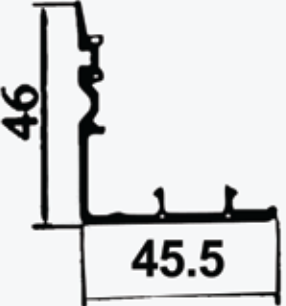
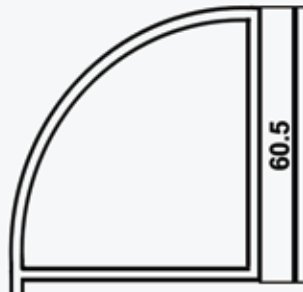
		 <p>NAME : 150 door panel WEIGHT : 0.93kg/m</p>
<p><b>BAY CORNER ADAPTOR</b></p>	<p><b>ROUND BAY POLE</b></p>	<p><b>PANEL</b></p>
<p>Length 5.8 Mtr      0.52 Kg / Mtr</p>	<p>Length 5.8 Mtr      0.745 Kg / Mtr</p>	<p>Length 5.8 Mtr      0.58 Kg / Mtr</p>
		
<p><b>COUPLER "I" "H"</b></p>	<p><b>DOOR INTERLOCK</b></p>	<p><b>SQUARE PAY POLE</b></p>
<p>Length 5.8 Mtr      0.30 Kg / Mtr</p>	<p>Length 5.8 Mtr      0.28 Kg / Mtr</p>	<p>Length 5.8 Mtr      0.78 Kg / Mtr</p>

## RE-INFORCEMENT

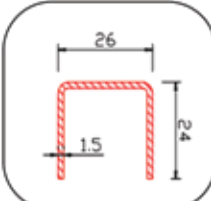
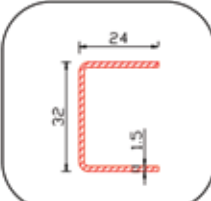
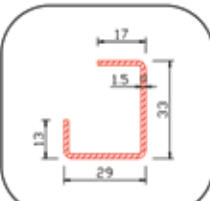
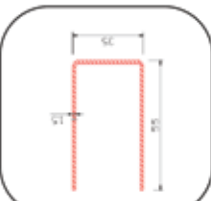
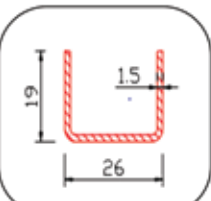
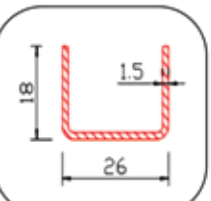
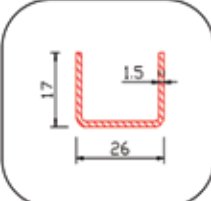
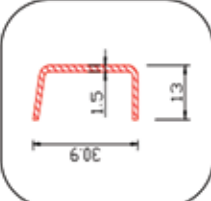
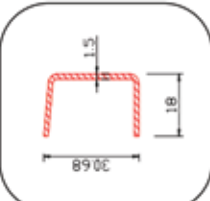
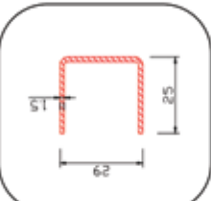
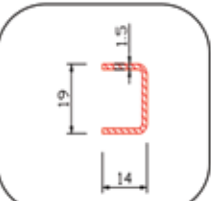
					
<p>WINDOW FRAME 310100</p>	<p>WINDOW OUTWARD SASH 310200</p>	<p>MULLION 310300</p>	<p>DOOR OUTWARD SASH 310500</p>	<p>2 TRACK FRAME 300100</p>	<p>2.5 TRACK FRAME 300200</p>
					
<p>3 TRACK FRAME 300300</p>	<p>57 SASH 300400</p>	<p>66 SASH 300500</p>	<p>86 SASH 300600</p>	<p>SCREEN SASH 300700</p>	

# PROJECT SLIDING SERIES

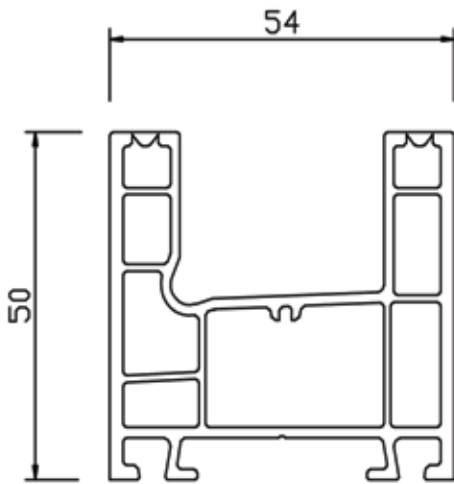

**NAME :54 frame**  
**WEIGHT:0.88kg/m**

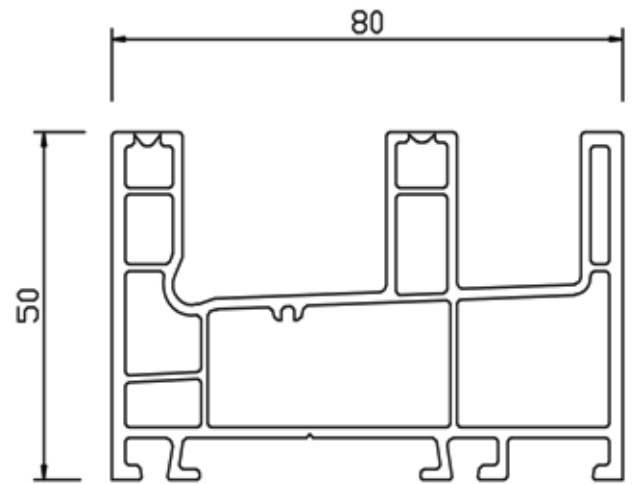

**NAME :80 frame**  
**WEIGHT:1.13kg/m**

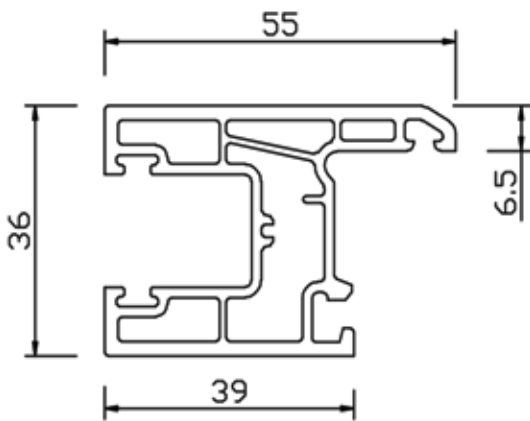

**NAME :54 frame**  
**WEIGHT:0.73kg/m**

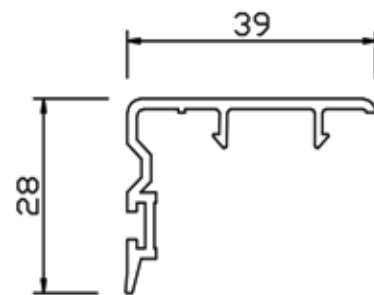

**NAME :80 interlock**  
**WEIGHT:0.20kg/m**

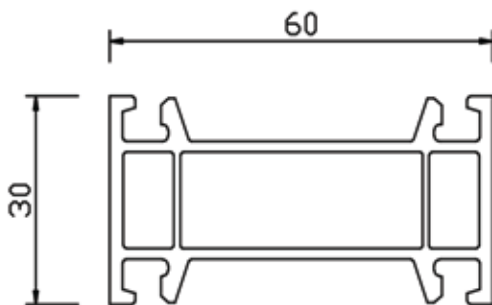

**NAME :60 small frame**  
**WEIGHT:0.64kg/m**

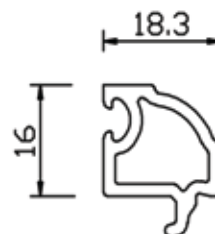

**NAME :80 glazing bead**  
**WEIGHT:0.20kg/m**

# LOTUS CASEMENT SERIES



60 casement assembly drawing

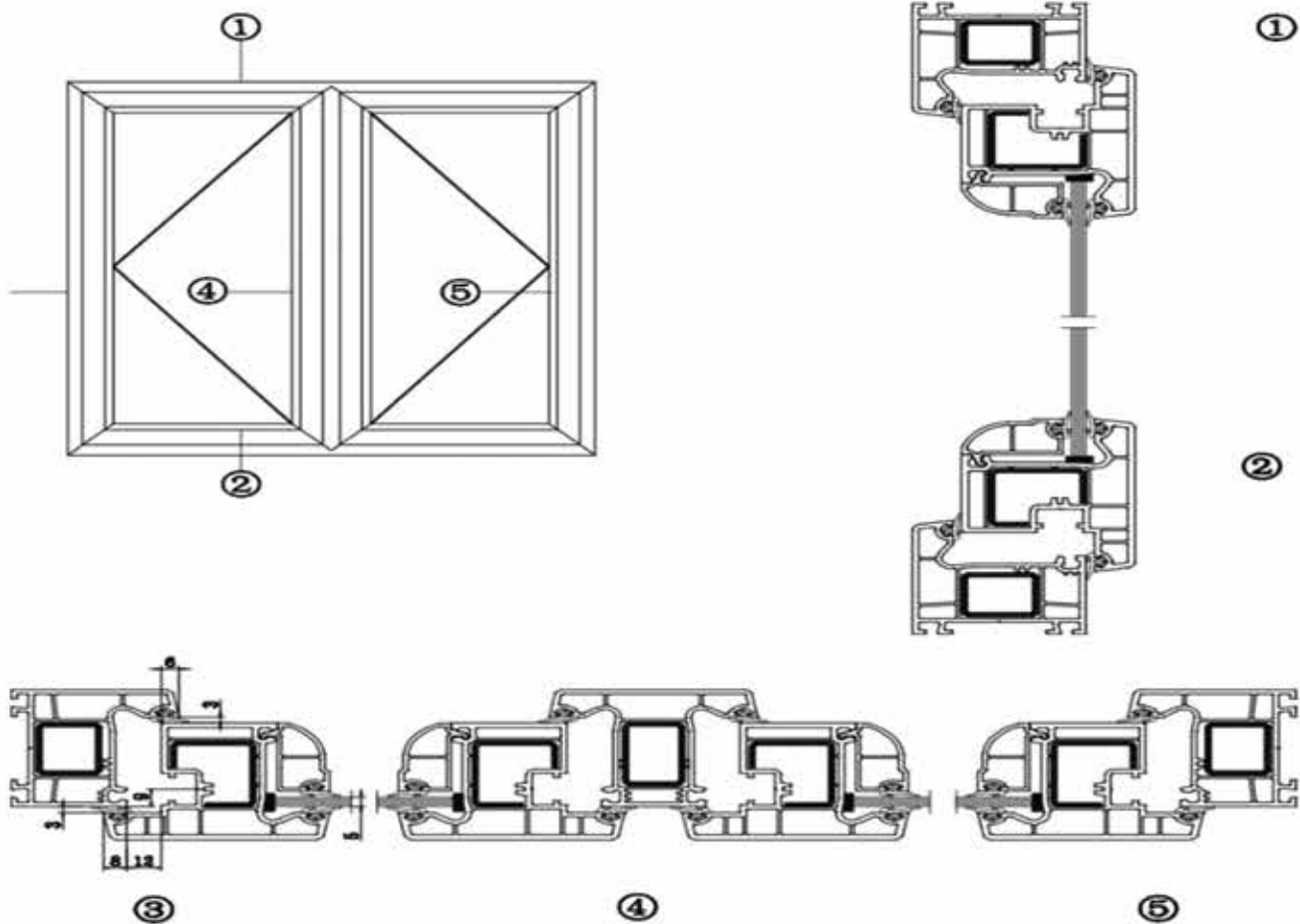

60 casement assembly drawing

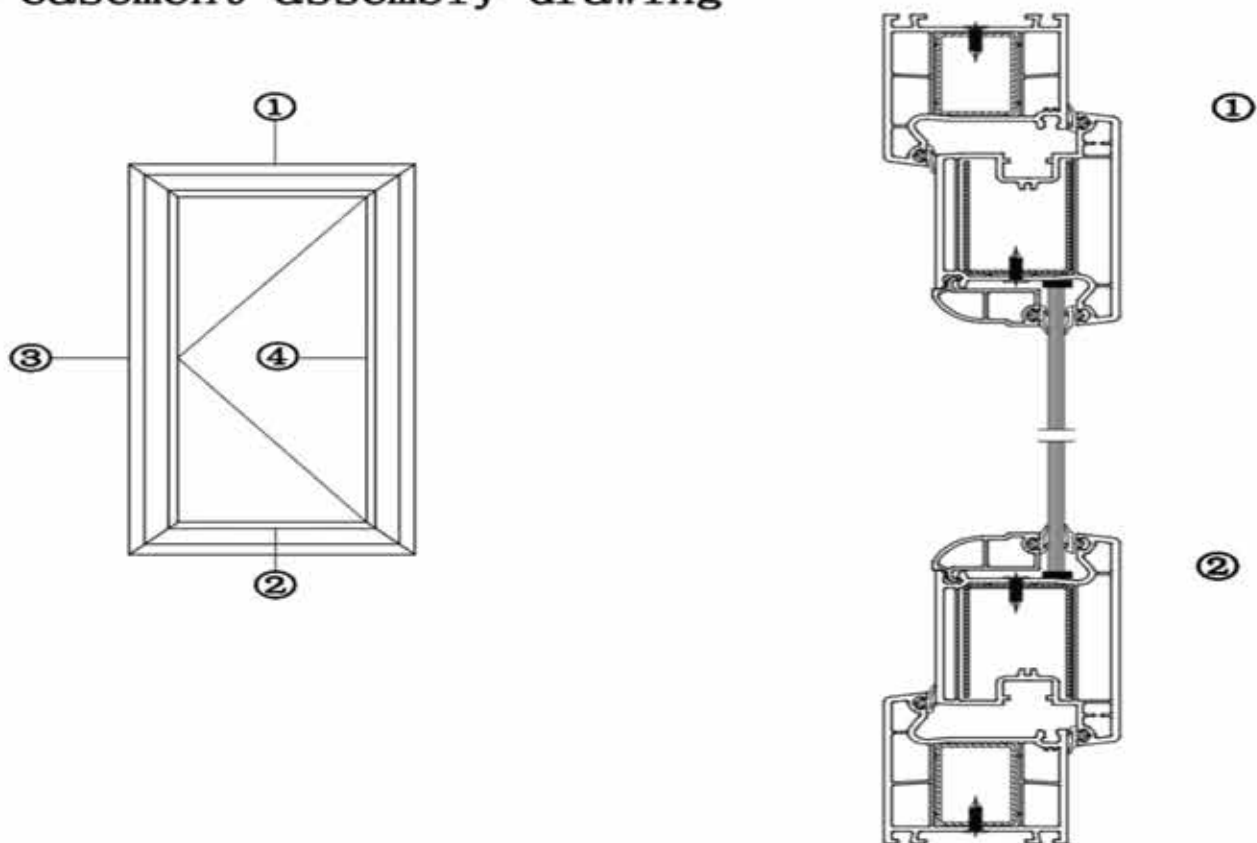

# LOTUS SLIDING SERIES



62 sliding assembly drawing

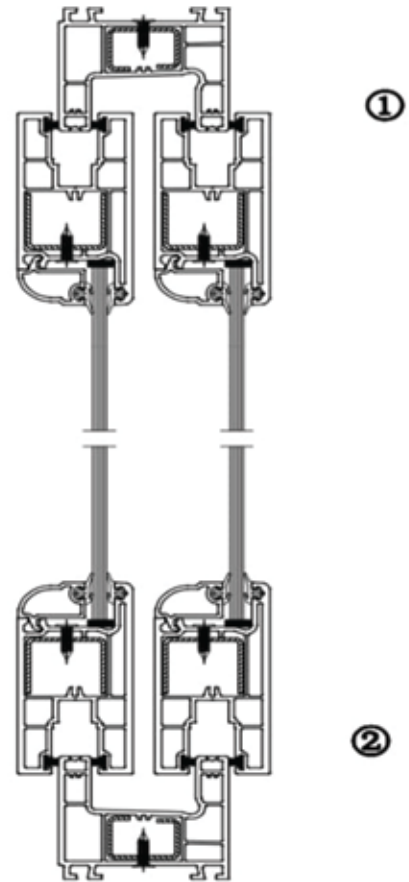
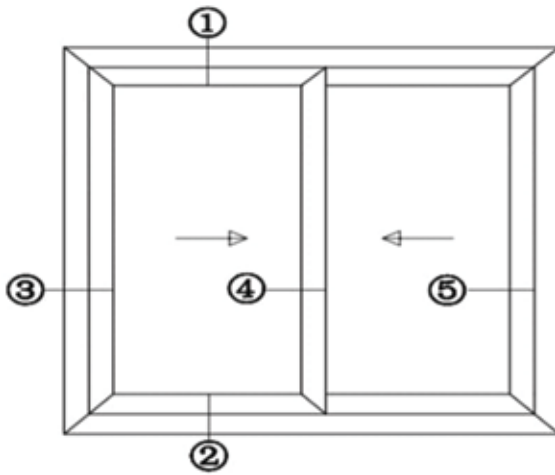

90 sliding assembly drawing

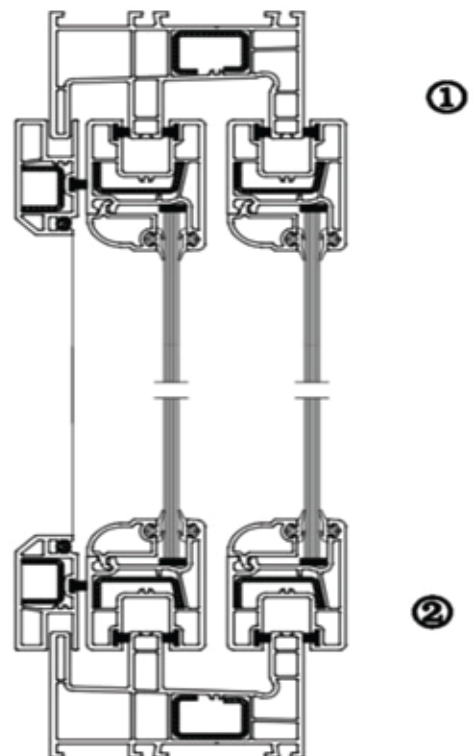
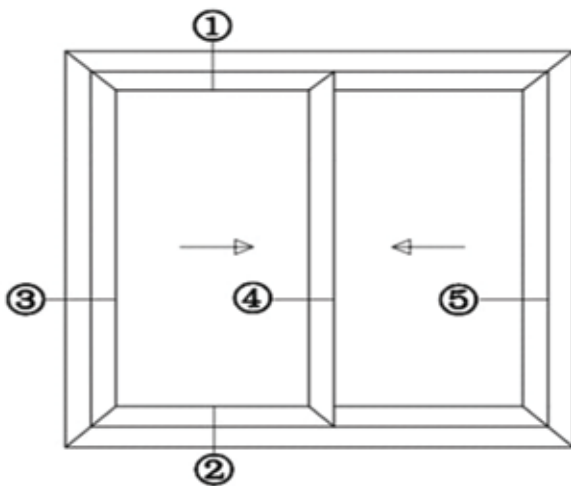

# 80 sliding assembly drawing

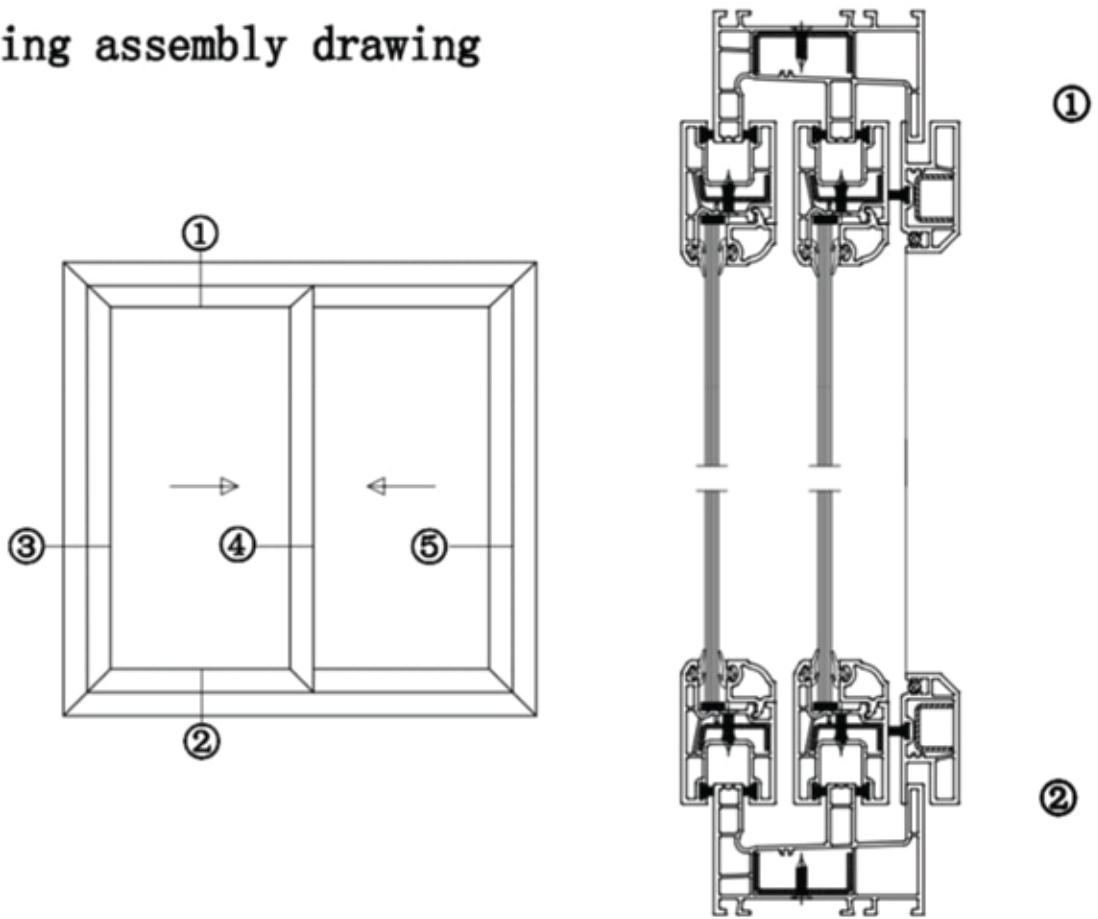

## UNITECH PROFILE STRENGTHS



**Impact Resistant**



**Corrosion Resistant**



**Insect Resistant**



**Water Resistant**



**Thermal Resistant**



**Fire Resistant**



**Sound Proof Resistant**



**Eco Friendly**



**Energy Efficient**



**Lifetime Durability**



**Long Lasting Strength**



**Weather Proof**

# COLOR PROFILE







WE ARE SPECIALIST  
IN THE FIELD OF MANUFACTURING  
**UPVC PROFILES**





## GET IN TOUCH WITH US

 98409 36516 / 91764 30442

 unitechprofile@gmail.com

 **Factory:** No. 6/11-A, Pulavanpadi Road, Ponni nagar, Thatchur, Aarani, Thiruvannamalai, Tamilnadu - 632326. | Cell: 99520 10586

 **Chennai Warehouse:** No.7, Nagalkeni Thiruneermalai Road, Chrompet, Chennai - 600044. | Cell: 73056 48542

 **Trichy Warehouse:** No.64, Thiruvallur Nagar, Kalpalayam Road, Mannachanallur, Trichy - 621005. | Cell: 73585 52354

 [www.unitechprofiles.com](http://www.unitechprofiles.com)

  
**UNITECH**  
**PROFILES** 

